

Conventional Duct Smoke Detectors



Description

The Gamewell conventional duct smoke detectors provide early detection of smoke and products of combustion present in air moving through an HVAC duct. These devices are designed for prevention of smoke recirculation by the air handling systems. Fans, blowers and complete systems may be shut down, or activated into fire mode operation in the event of smoke detection.

The Gamewell Duct Smoke Detector may use a photoelectric, or ionization detector head. A visual alarm indicator is mounted on the housing front for status indication. A manual reset switch is provided on the front of the detector.

Air sampling is accomplished by two tubes which protrude into the duct. An exhaust tube of one standard length of 7.5" (19.05 cm) is provided with the detector housing. Intake sampling tubes, which must be ordered separately, are supplied in three standard lengths: 2.5, 5.0, or 10.0 feet (0.76, 1.524 or 3.048 m).

Standard features of the duct type smoke detectors include a local red LED alarm indicator, local functional test/reset capability, provisions for remote test, remote alarm indication, and connections for remote reset switch.

Engineer's Specifications

Duct smoke detectors shall be the Gamewell series: for two-wire or four-wire 24 VDC operation use model 30954 (ionization) or 30955 (photoelectric); universal voltage models are 70957-01 (ionization) or 70958-01 (photoelectric). The detectors shall be Listed by Underwriters Laboratories per UL 268A. The detectors shall operate at air velocities from 300 to 4,000 feet (31.44 to 1219.2 m) per minute.

The duct detector housing shall have a metal chassis with a plastic cover, and mechanical installation may be performed without removal of the detector cover.

Visual indication of alarm must be provided on the detector front mounted at a 30° slant to provide a wide viewing angle. A manual reset/test switch shall be located on the front of the device.

Detector heads shall not require additional filters, or screens which must be maintained. The housing shall contain a detector base which will accept photoelectric or ionization heads. Terminal connections shall be of the screw type and be a minimum of a #6 screw. Terminals shall be provided for remote alarm indication and remote reset/test switches. All wiring must comply with local codes and regulations.

Features

- Photoelectric or Ionization.
- Two form-c alarm contacts.
- Remote reset and test.
- 24 VDC or universal input models.
- Remote alarm LED.
- Form-C trouble contact.
- Two or four-wire operation.
- Mounting template and hardware provided.

Listings

Listings and approvals below apply to the basic Conventional Duct Smoke Detectors. In some cases, certain modules may not be listed by certain approval agencies, or listing may be in process. Consult factory for latest listing status.

- UL Listed:

Gamewell 
A 150-Year Tradition

Wiring Diagram

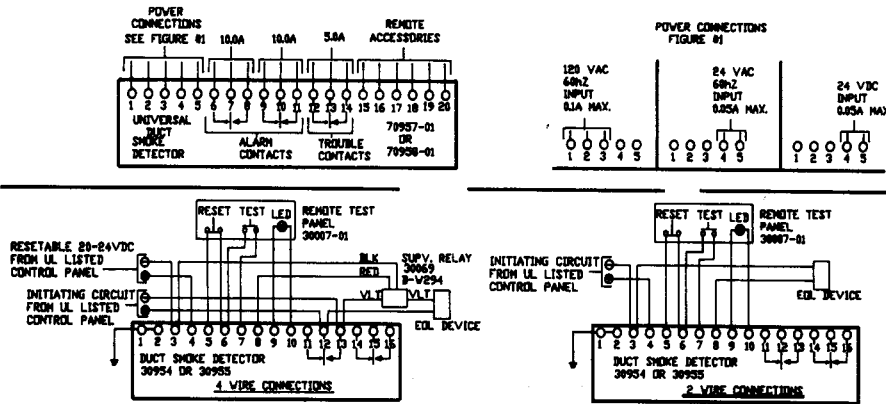

Ordering Information

- 30954 Ionization smoke detector for air duct, 2-wire or 4-wire, 24 VDC (2650-560).
- 30955 Photoelectric smoke detector for air duct, 2-wire or 4-wire, 24 VDC (2650-561).
- GW-30203-01 Remote LED alarm indicator, 2 VDC, for models 30954 and 30955.
- GW-30007-01 Remote test station, for models 30954 and 30955.
- GW-30069 End-of-line relay for power supervision, 24 VDC, for models 30954 and 30955.
- GW-70957-01 Ionization duct smoke detector, universal voltage 110 VAC, 24 VAC, 24 VDC, (RWH-N).
- GW-70958-01 Photoelectric duct smoke detector, universal voltage 110 VAC, 24 VAC, 24 VDC, (RWH-P).
- GW-30203 Remote LED alarm indicator, 24 VDC, for models 70957-01 and 70958-01.
- GW-30003 Remote test station for models 70957-01 and 70958-01.
- GW-70896-02 Sampling tube, 2.5 ft. (0.762 m).
- GW-70896-05 Sampling tube, 5.0 ft. (1.524 m).
- GW-70896-10 Sampling tube, 10.0 ft. (3.048 m).
- GW-71034 Ionization detector head replacement.
- GW-72247 Duct detector enclosure (WP-1) (see CS-2308).



A Honeywell Company

The Gamewell Company
 12 Clintonville Road
 Northford, CT 06472-1610
 Phone: 203-484-7161
 Fax: 203-484-7118
 www.gamewell.com

A Honeywell Company
 © 2004 Gamewell

Specifications

Ambient temperature
 30°F to 120°F (0°C to 49°C).

Humidity
 10% to 85% relative humidity.

Material
 16-gauge steel back-box. Plastic ABS-640V0 cover.

Finish
 Textured grey finish with clear cover.

Dimensions
 10.0" H x 8.25" W x 2.25" D (cm: 25.4 H x 21.0 W x 5.7 D).

Maximum net weight
 4.0 lbs. (1.814 kg).

Radioactive element
 For ionization versions only: americium 241 (1.0 microcuries).

Air velocity
 300 to 400 feet (m: 91.44 to 121.92) per minute.

Pressure differential
 0.01 – 1.2 inches (cm: 0.01 – 3.048) of water.

Power requirements
Model 30954 and 30955: 24 VDC operation at 0.00005 A standby, 0.05 A alarm.
Model 70957-01 and 70958-01: 115 VAC operation at 0.02 A standby, 0.035 A alarm; 24 VAC operation at 0.061 standby, 0.16 A alarm; 24 VDC operation at 0.025 A standby, 0.07 A alarm.

Relay contact rating
Model 30954 and 30955: alarm contacts, two Form-C: rated at 1.0 amp, 30 VDC.
Model 70957-01 and 70958-01: alarm contacts, two Form-C rated at 10.0 A at 115 VAC resistive; trouble contacts, one Form-C rated 4.0 amps at 115 VAC resistive.

Specifications and wiring information are provided for information only and are believed to be accurate. Gamewell assumes no responsibility for their use. Data and design are subject to change without notice. Installation and wiring instructions shipped with the product shall always be used for actual installation. For more information, contact Gamewell.