



LTC 89xx Series Allegiant Matrix/Control Systems - Modular



- ▶ 4096 Camera by 512 monitor switching
- ▶ Modular construction
- ▶ Powerful alarm handling capabilities
- ▶ SalvoSwitching and SatelliteSwitch capability
- ▶ Includes Windows-based configuration software

The LTC 8900 Series Allegiant Video Switcher/Control Systems are powerful full matrix switchers, capable of displaying video from any camera on any monitor, either manually or via independent automatic switching sequences. By using the LTC 8901 series CPU and the LTC 8943 series PC, the standard system can be enhanced to include dual/redundant CPU/Power supply with automatic hot-switchover capabilities.

Functions

General Construction

The LTC 8900 Series provides versatile modular construction accommodating up to 4096 camera inputs, 512 monitor outputs, 64 keyboards, 1024 alarm points, and a computer interface port. The robust design utilizes a separate CPU bay with its own power supply.

Dual/Redundant System

For situations where complete system failure cannot be tolerated, we offer the dual redundant LTC 8901 CPU. This CPU unit incorporates a secondary CPU/power supply. In the event of a primary CPU or power supply failure, the system switches over automatically to the backup CPU or power supply. The system uses an independent PC that continuously monitors the CPUs for failure and performs a hot-switchover if needed. You

can also manually change CPUs using the preloaded software or via a front panel slide switch.

Sequencing Capabilities

These systems can be programmed with up to 256 sequences, which can be run independently of each other in either a forward or reverse direction. Any of the sequences can utilize the SalvoSwitching capability, where any number of system monitors may be selected to switch as a group. Using the supplied software, sequences can automatically activate and deactivate based upon the day or the time of day.

Camera Control

On-site receiver/drivers permit control of pan, tilt, zoom, multiple pre-positions, four auxiliaries, autopan, and random scan. An integral local test function is also a standard feature, greatly simplifying installation. The LTC 8900 Series also supports the AutoDome® series of integral pan/tilt/zoom (PTZ) dome cameras, providing full proportional variable speed control. In addition, all AutoDomes allow setup programming directly from the Allegiant system keyboards.

Bilinx® Capability

When combined with an LTC 8016 Allegiant Bilinx Data Interface unit, these switcher/controllers support

operations using Bilinx communication. With Bilinx, PTZ control is accomplished using a bidirectional communication protocol embedded in the video signal of Bosch Dinion® and AutoDome CCTV cameras. In addition, Bilinx uses the standard video cable to transmit alarm and status messages from the cameras, providing superior performance without the need for separate data transmission cables.

Macro Capabilities

The LTC 8900 system provides powerful macro capabilities. Macros can be activated using Allegiant Series system keyboards, timed event functions, and alarm activations. The macros can also be activated via function icons when using the optional LTC 8850/00 GUI Software.

Alarm Capabilities

The LTC 8540/00 alarm interface unit allows external contact closure or logic level input to automatically display cameras on a monitor or group of monitors. The supplied PC software includes the ability to combine multiple alarm operating modes within the same system. Alarm video may be selected to reset either manually or automatically. In addition, one can customize a 16-character alarm titles to designate the specific alarm condition.

System Operation

System operation and programming is accomplished using a full-function, ergonomically designed keyboard. Up to 64 keyboards may be used in the system. Built-in operator priority levels and the ability to restrict certain operators from controlling designated functions provide maximum flexibility.

Programming/Software Capabilities

The LTC 8900 Series includes a black outlined 48-character on-screen display for time/date, camera number, camera ID (16 characters), and monitor (12 characters) or status information. Over 1,000 characters

covering a multitude of languages, (including several hundred Chinese symbols) are available to help program camera ID and monitor titles. Using the supplied PC software, enhanced programming and switching features can be obtained. A user friendly spreadsheet format allows one to easily enter/change camera titles, operator names, timed events (128), system parameters, camera sequences, lockouts, and advanced alarm response programming. The software also provides the ability to enable an on-screen indicator for easy identification of controllable cameras. Another useful feature of the software is its ability to store or print (in real-time) programming information, system events, alarms, switching functions, sequence events, keyboard actions, and video loss information.

Expansion Capabilities

The LTC 8900 Series can serve as the Master or Slave Switcher in a SatelliteSwitch configuration. This innovative SatelliteSwitch feature enables a single LTC 8900 system to communicate with remotely located Satellite systems. Any Allegiant system can serve as a remote Satellite Switcher. This powerful feature permits the design of large distributed type systems. The main control site can view and control local cameras as well as cameras located at any of the remotely distributed Satellite sites. The Satellite sites can view and control only cameras associated with their local site. When used in this type of configuration, the main LTC 8900 system can access up to 256 Satellite sites.

Configuration Ordering Information

Please contact your local Bosch Sales office.

Certifications and Approvals

| | |
|--|--|
| Electromagnetic Compatibility (EMC) | Complies with FCC Part 15, ICES-003, and CE regulations |
| Product Safety | Complies with CE regulations, UL, CSA, EN, and IEC Standards |

Installation/Configuration Notes

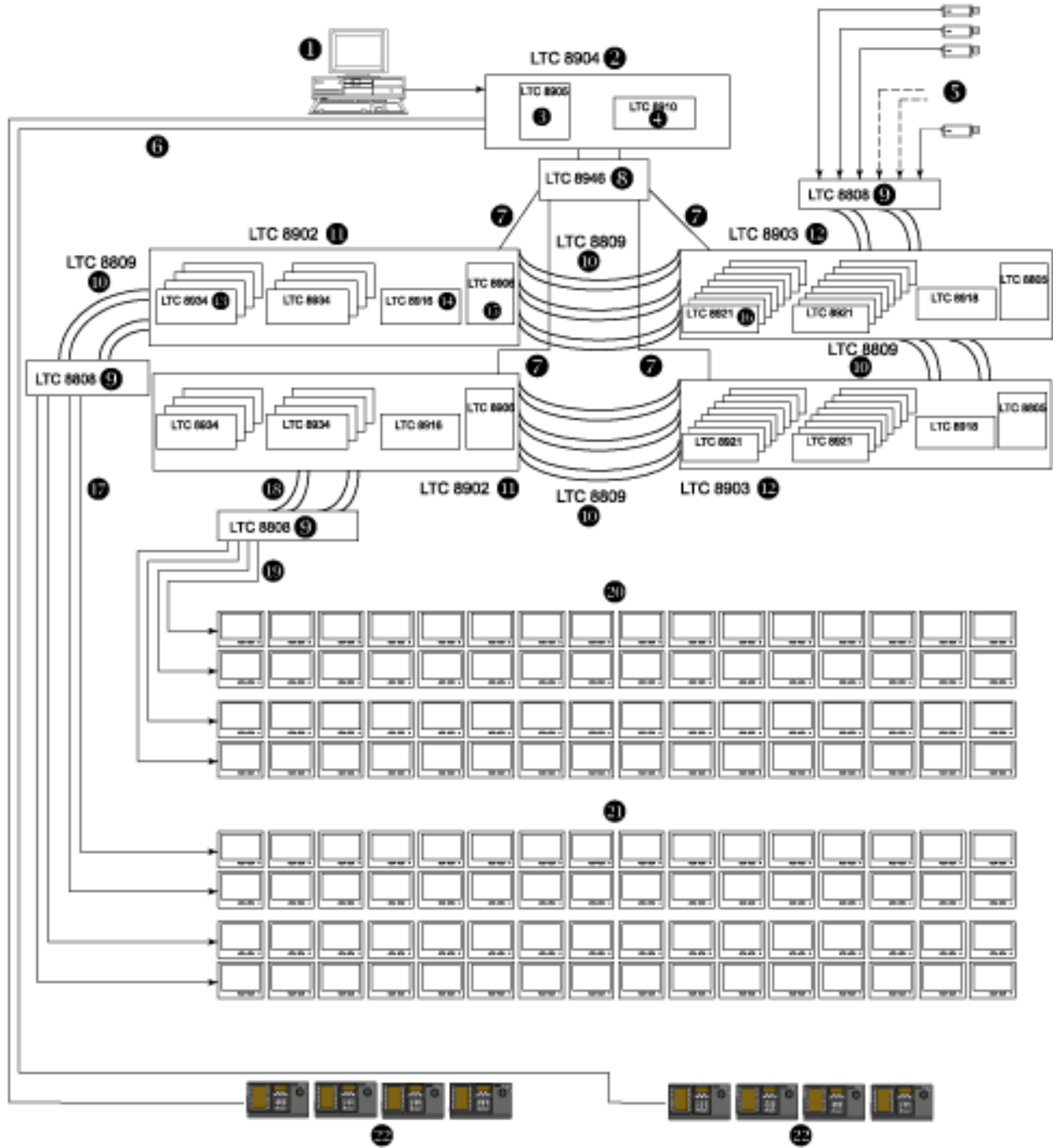

Typical Diagram of LTC 8904 Series System Configuration
(256 Cameras by 128 Monitors)

- | | | | | | | | |
|---|---|----|----------------------|---|-------------------|----|----------------------|
| 1 | Optional PC Running LTC 8059 Master Control Software for Windows or LTC 8850 GUI Software | 12 | Video Input Bay | 3 | Main Power Supply | 14 | Data Receiver Module |
| 2 | Main CPU Bay | 13 | Video Output Modules | 4 | Main CPU Module | 15 | Power Supply |
| | | | | 5 | Up to 256 Cameras | 16 | Video Input Modules |

- | | | | |
|-------------------------------------|---|-----------------------|---|
| 6 Multiple Data Cables to Keyboards | 17 Multiple Coax Cables to Monitor Groups | 8 Switch | 19 Multiple Coax Cables to Monitor Groups |
| 7 LAN Data Line | 18 Supplied Coax Ribbon Cables | 9 Video Panels | 20 System Monitors 65-128 |
| | | 10 Coax Ribbon Cables | 21 System Monitors 1-64 |
| | | 11 Video Output Bay | 22 System Keyboards |

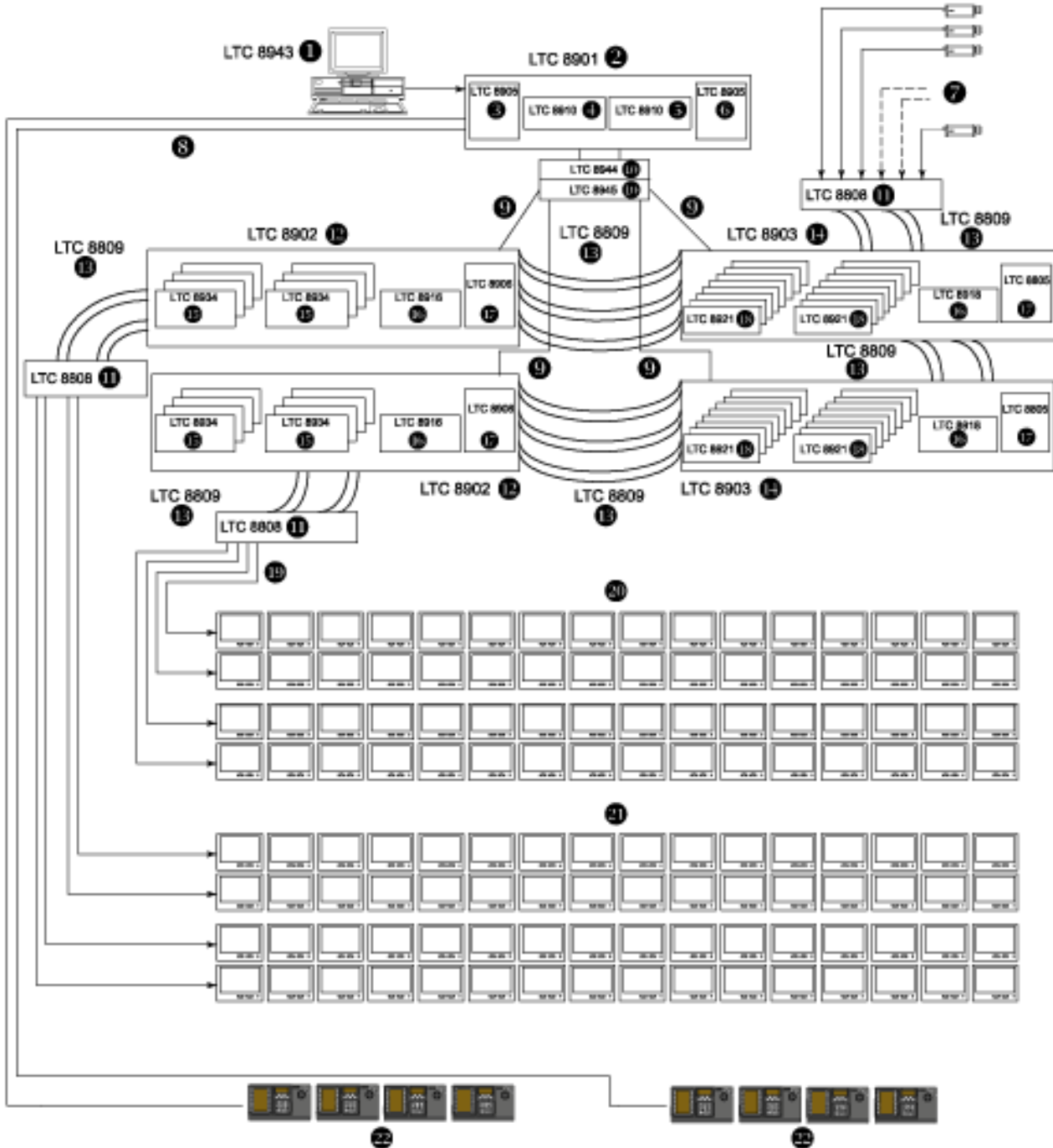

Typical Diagram of LTC 8901 Series Redundant System Configuration (256 Cameras by 128 Monitors)

- | | | | |
|-------------------------------------|-----------------------|---------------------|-------------------------|
| 1 PC Running Configuration Software | 12 Video Output Bay | 3 Main Power Supply | 14 Video Input Bay |
| 2 Main CPU Bay | 13 Coax Ribbon Cables | 4 Main CPU Module | 15 Video Output Modules |

| | | | |
|-----------------------|-------------------------|-------------------------------------|---|
| 5 Backup CPU Module | 16 Data Receiver Module | 8 Multiple Data Cables to Keyboards | 19 Multiple Coax Cables to Monitor Groups |
| 6 Backup Power Supply | 17 Power Supply | 9 LAN Data Line | 20 System Monitors 65-128 |
| 7 Up to 256 Cameras | 18 Video Input Modules | 10 Switch | 21 System Monitors 1-64 |
| | | 11 Video Panels | 22 System Keyboards |

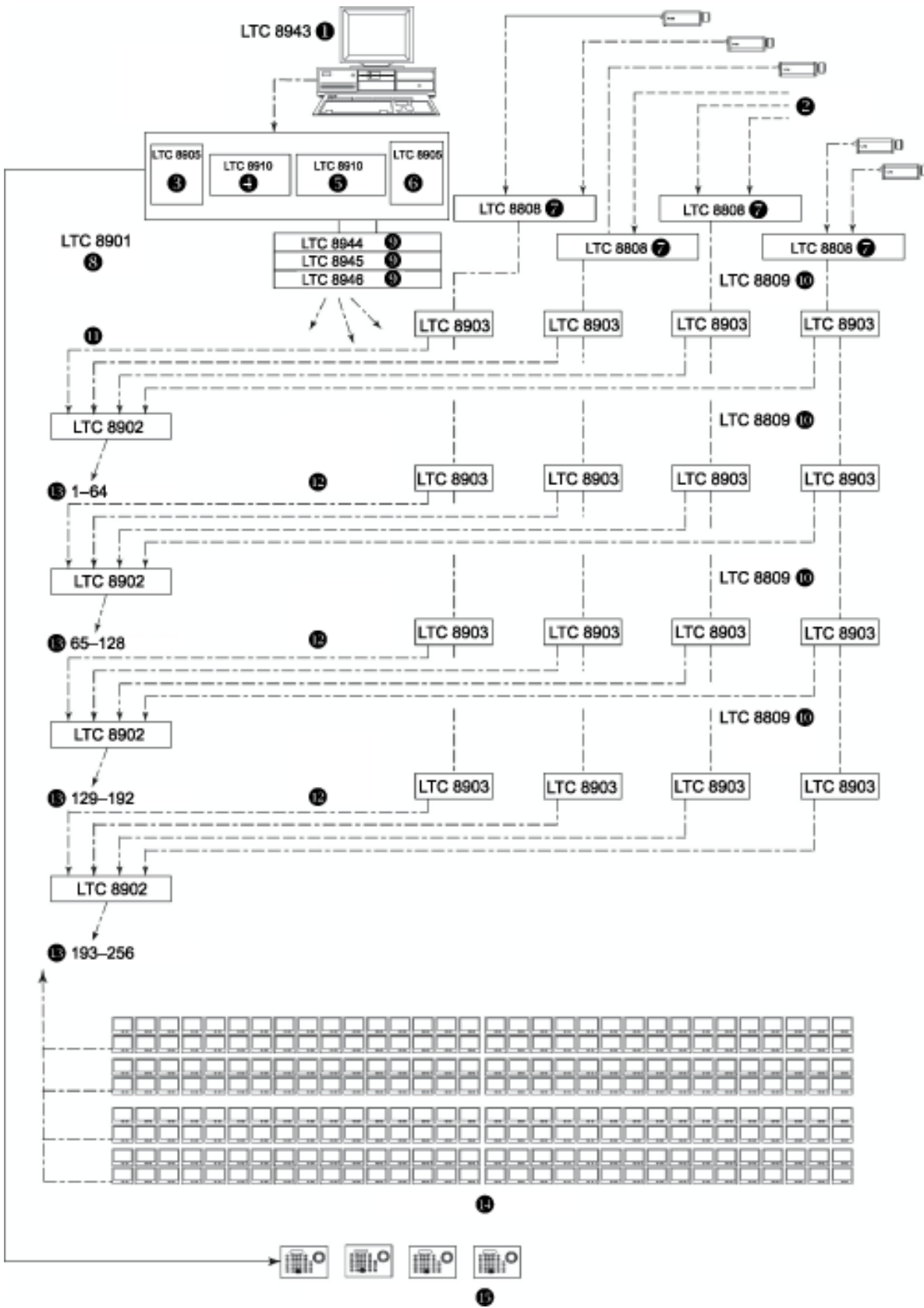

Typical Diagram of LTC 8901 Series Redundant System Configuration (1024 Cameras by 256 Monitors)

| | | | | | | | |
|---|-----------------------------------|----|-----------------------------|---|---------------------|----|---------------------------|
| 1 | PC Running Configuration Software | 9 | Switch | 5 | Backup CPU Module | 13 | To Monitors |
| 2 | Additional Cameras | 10 | Coax Ribbon Cables | 6 | Backup Power Supply | 14 | Up to 512 System Monitors |
| 3 | Main Power Supply | 11 | LAN Data Lines to All Bays | 7 | Video Panels | 15 | Up to 64 System Keyboards |
| 4 | Main CPU Module | 12 | Supplied Coax Ribbon Cables | 8 | Main CPU Bay | | |

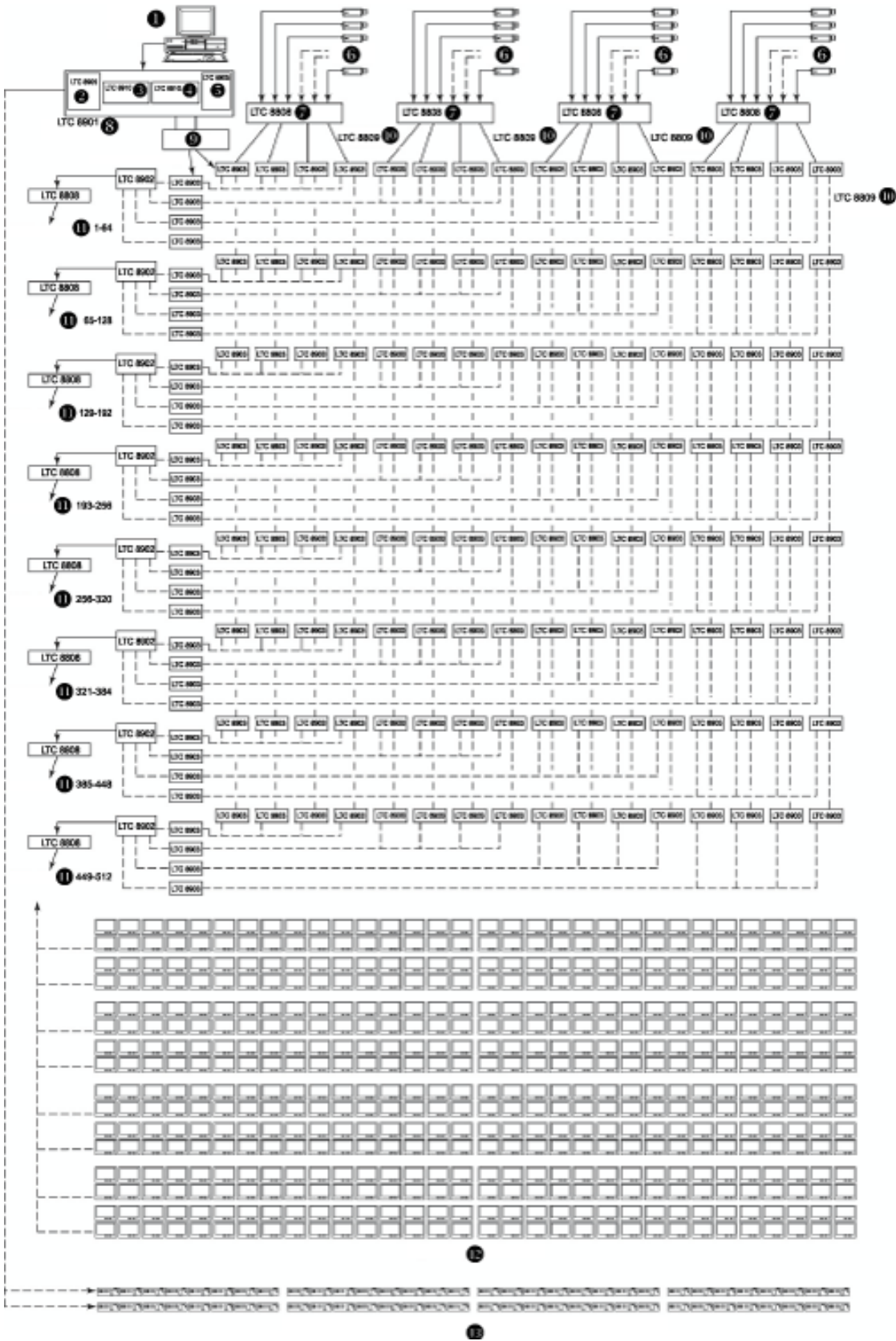

Typical Diagram of LTC 8901 Series Redundant System Configuration (4096 Cameras by 512 Monitors)

- | | | | |
|---|-----------------------------------|----|---|
| 1 | PC Running Configuration Software | 7 | Video Panels |
| 2 | Main Power Supply | 8 | Main CPU Bay |
| 3 | Main CPU Module | 9 | LAN Switches |
| 4 | Backup CPU Module | 10 | Coax Ribbon Cables |
| 5 | Backup Power Supply | 11 | To Monitors |
| 6 | Additional Cameras | 12 | Up to 512 System Monitors |
| | | 13 | Up to 64 System Keyboards (Using LTC 8714 and LTC 8715 Series Port Expanders) |

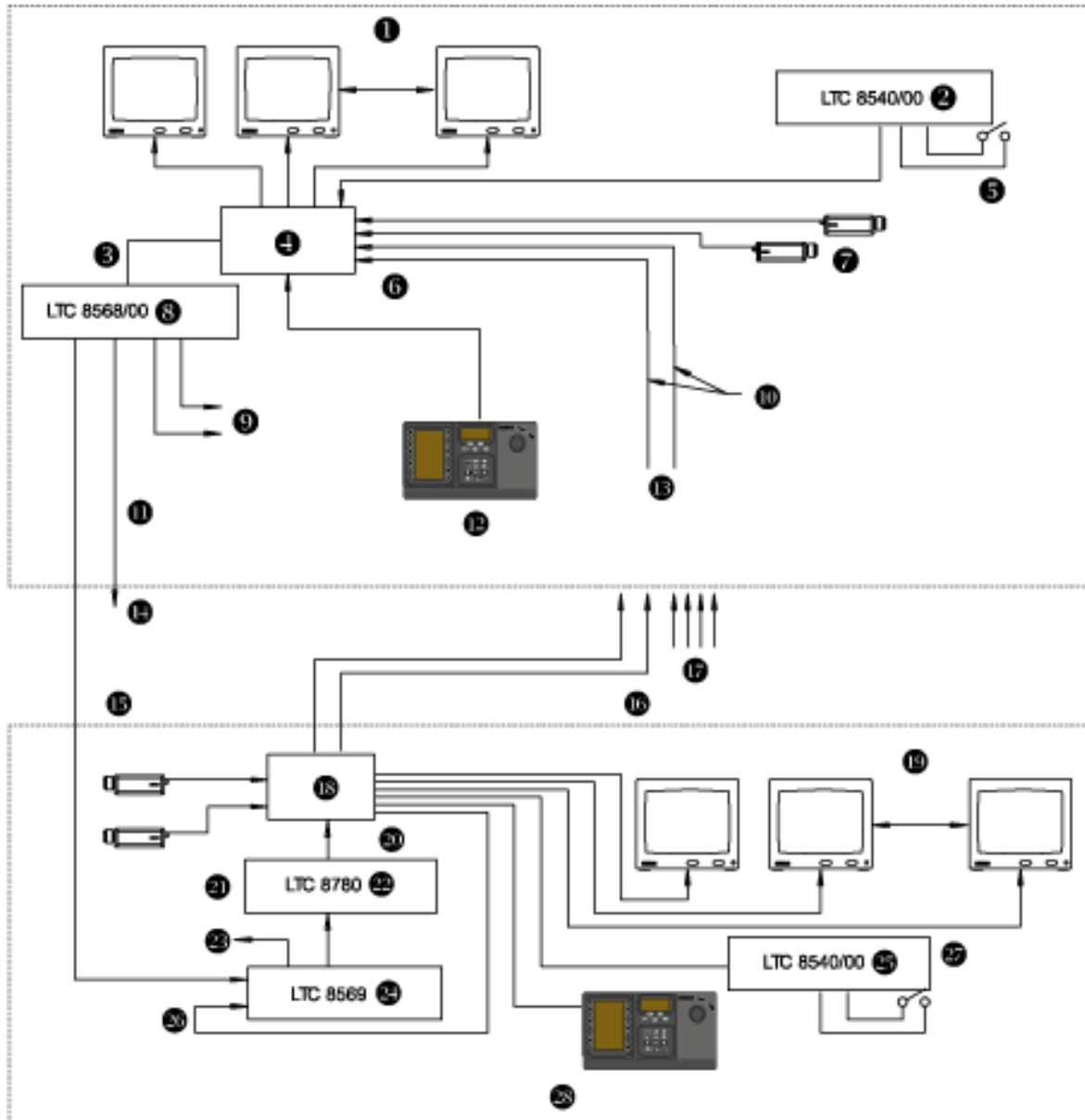

*Allegiant Satellite Switching System
(1024 Cameras by 256 Monitors)*

| | | | |
|----|---|----|---|
| 1 | Monitor Outputs | 15 | Pan/Tilt/Zoom and Satellite Control Data |
| 2 | Alarm Interface Unit | 16 | Monitor Outputs Used as Video Trunk Lines to Main Control Site |
| 3 | Pan/Tilt/Zoom and Satellite Control Data | 17 | Video Trunk Lines from other Satellite Locations |
| 4 | Allegiant Main CPU Bay | 18 | Any Model Allegiant Main Bay |
| 5 | Alarm Inputs May Activate Either Local or Satellite Video Main Control Center's Monitor | 19 | Local Monitor |
| 6 | Signal Distribution Unit | 20 | Console Port Input |
| 7 | Inputs Used for both Local and Trunk Lines | 21 | Satellite Data Line |
| 8 | Local Camera Video | 22 | Data Converter Units |
| 9 | To any Local Pan/Tilt/Zoom Camera Sites | 23 | To any Local Pan/Tilt/Zoom Camera Sites |
| 10 | Multiple Video Coax | 24 | Code Merger Unit |
| 11 | Up to 1.5 km (5000 ft) using 1sq mm (18 AWG) Shielded Twisted Pair (Belden 8760 or Equivalent) | 25 | Alarm Interface Unit |
| 12 | Allegiant Keyboard Controls any Local or Remote Camera on any Local Monitor (Video and Pan/Tilt/Zoom) | 26 | Local Pan/Tilt/Zoom Control Data Line |
| 13 | Multiple Video Trunk Lines from each Remote Satellite Location | 27 | Alarm Interface Unit only Local Video on Local Monitors |
| 14 | One Line to Each Remote Satellite System Location | 28 | Allegiant Keyboard Controls any of the Local Cameras on any of the Local Monitors (Video and Pan/Tilt/Zoom) |

Technical Specifications

LTC 8900 Series System Specifications

Capacities

| | |
|------------------|------|
| Video Inputs | 4096 |
| Video Outputs | 512 |
| Keyboards | 64 |
| Alarm Inputs | 1024 |
| Receiver/Drivers | 4096 |

Electrical

| | | | |
|--|---|-------|--------|
| Input Voltage Level | 0.5 V _{p-p} to 2 V _{p-p} (composite negative sync) | | |
| Gain | Unity ± 2% (75 Ohm terminated) | | |
| Pulse/Bar Ratios ¹ | Min.: | Nom.: | Max.: |
| | 94% | 98% | 106% |
| 2T Pulse K Factor ¹ | Min.: | Nom.: | Max.: |
| | | 0.2% | 2.5% |
| Bar Amplitude (IRE) ¹ | Min.: | Nom.: | Max.: |
| | 96 | 98 | 104 |
| Sync Amplitude (% Bar) ¹ | Min.: | Nom.: | Max.: |
| | 36% | 39% | 44% |
| Field Time Waveform Distortion ¹ | 2% maximum | | |
| Line Time Waveform Distortion ¹ | 1% maximum | | |
| Short Time Waveform Distortion ¹ | 2% maximum | | |
| Long Time Waveform Distortion ¹ | 0.8% maximum | | |
| Video Bandwidth (-3 dB) | 25 MHz | | |
| Frequency Response | ± 0.5 dB to 12 MHz | | |
| Signal-to-Noise-Ratio ¹ | 70 dB at 3.58 MHz unified un-weighted minimum | | |
| Crosstalk (at 3.58 MHz) | Typical: -72 dB, adjacent channel: -50 dB (typical) | | |
| Hum | 60 dB below the composite 1 V _{p-p} video signal from 60 Hz to 6 MHz | | |
| Differential Gain ¹ | Min.: | Nom.: | Max.: |
| | | 0.6% | 2% |
| Differential Phase ¹ | Min.: | Nom.: | Max.: |
| | | 0.6° | 1.3° |
| Chrominance Luminance Gain | Min.: | Nom.: | Max.: |
| | 94% | 100% | 109% |
| Chrominance Luminance Delay ¹ | Min.: | Nom.: | Max.: |
| | -33 ns | +3 ns | +33 ns |
| Luminance Nonlinearity ¹ | Min.: | Nom.: | Max.: |
| | | 0.3% | 4% |
| Switching | Crosspoint matrix | | |
| DC Output | 0 V | | |

¹ Meets EIA/TIA - 250C Medium Haul Standard for 1024 cameras x 64 monitors.

Environmental

| | | |
|--------------------|---------------------------------------|------------------------------|
| Temperature | Operating | 4 to 50°C (40°C to 122°F) |
| | Storage | -40 to 60°C (-40°C to 140°F) |
| Altitude | 4500 m (15,000 ft) | |
| Humidity | 0 to 95 % relative, non-condensing | |
| Vibration | 3 g swept sine wave, 15 Hz to 2000 Hz | |
| Shock | 50 g, 11 m/s, ½ sine wave | |

LTC 8904 CPU Equipment Bay

The LTC 8904/60 and LTC 8904/50 include the equipment rack, LTC 8910/00 microprocessor module, LTC 8905/90 power supply, and LTC 8917/00 relay module.

Electrical

| Model No. | Rated Voltage | Voltage Range | Nominal Power ¹ |
|-------------|-----------------------|---------------|----------------------------|
| LTC 8904/60 | 120 VAC, 50/60 Hz | 100 to 140 | 30 W |
| LTC 8904/50 | 220-240 VAC, 50/60 Hz | 198 to 264 | 30 W |

¹. Power at rated voltage fully loaded.

Connectors

| | |
|-----------------|--|
| Controller Port | RS-232 port for an external PC or computing device |
| Console | RS-232 port for an external computer or a computing device (default = 19,200 baud) |
| Alarm | RS-232 port for an Allegiant alarm accessory unit (default = 19,200 baud) |
| Bi-Phase | TTL level, high-speed control data output (BiPhase) for interface to an Allegiant series signal distribution units (data clock rate = 31.25 kHz) |
| COM Ports | Two RS-485 ports for an external Allegiant accessory use |
| Keyboards | Eight (8), 6-pin RS-485 ports for an Allegiant keyboard use (default = 9600 baud) |
| LAN | RJ-45 high-speed LAN port for interface to LTC 8902 Series and LTC 8903 Series bays via LTC 8946/90 LAN hub |

Components

Equipment Rack

| | |
|------------------------|---|
| Dimensions (W x D x H) | EIA 48 cm (19 in.) rack, 440 x 394 x 86 mm (17.3 x 15.5 x 3.4 in.) |
| Weight | 7.2 kg (15.85 lb) |
| Construction | Metal case with plastic panel |
| Finish | Charcoal |

Microprocessor Module (LTC 8910/00)

| | |
|--------------------|-------------------------------|
| Dimensions (D x H) | 300 x 250 mm (11.8 x 9.8 in.) |
| Weight | 0.5 kg (1.1 lb) |

Power Supply (LTC 8905/90)

Relay Module (LTC 8917/00)

Dimensions (D x H) 300 x 250 mm (11.8 x 9.8 in.)

Front Panel Indicators Power, CPU activity

LTC 8901 Series CPU Equipment Bay

The LTC 8901/60 and LTC 8901/50 include the equipment rack, dual LTC 8910/00 microprocessor modules, dual LTC 8905/90 power supplies, and one LTC 8917/00 relay module.

Electrical

| Model No. | Rated Voltage | Voltage Range | Nominal Power ² |
|-------------|-----------------------|---------------|----------------------------|
| LTC 8901/60 | 120 VAC, 50/60 Hz | 100 to 140 | 30 W |
| LTC 8901/50 | 220–240 VAC, 50/60 Hz | 198 to 264 | 30 W |

2. Power at rated voltage fully loaded.

Connectors

| | |
|------------------|---|
| Controller Ports | Two (2), RS-232 ports for an LTC 8943 PC controller interface |
| Console | RS-232 port for an external computer or a computing device (default = 19,200 baud) |
| Alarm | RS-232 port for an Allegiant alarm accessory unit (default = 19,200 baud) |
| Switch Ctrl | Digital interface port for the LTC 8943 PC controller |
| Bi-Phase | TTL level, hi-speed control data output (Bi-Phase) for interface to an Allegiant series signal distribution units (data clock rate = 31.25 kHz) |
| COM Ports | Two (2), RS-485 port for an external Allegiant accessory use |
| Keyboards | Eight (8), 6-pin RS-485 ports for an Allegiant keyboard use (default = 9600 baud) |
| LAN | Two RJ-45 high-speed LAN ports for interface to LTC 8902 Series and LTC 8903 Series bays via LTC 8944/92 and LTC 8945/92 LAN Switches |

Components

Equipment Rack

| | |
|------------------------|--|
| Dimensions (W x D x H) | EIA 48 cm (19 in.) rack, 440 x 394 x 86 mm (17.3 x 15.5 x 3.4 in.) |
| Weight | 8 kg (17.6 lb) |
| Construction | Metal case with plastic panel |
| Finish | Charcoal |

Microprocessor Modules (Two—LTC 8910/00)

| | |
|--------------------|-------------------------------|
| Dimensions (D x H) | 300 x 250 mm (11.8 x 9.8 in.) |
| Weight | 0.5 kg (1.1 lb) |

Power Supplies (Two—LTC 8905/90)

Relay Module (LTC 8917/00)

Dimensions (D x H) 300 x 250 mm (11.8 x 9.8 in.)

Front Panel Indicators

Primary power
Primary fault
Back-up power
Back-up fault
Primary CPU in-use
Controller activity
Back-up CPU in-use
Auto-select mode
Primary CPU activity
Fault buzzer
Back-up CPU activity

Rear Panel Indicators

Relay outputs³
Primary CPU fault
Back-up power supply failure
Back-up CPU fault
Any failure
Primary power supply failure

3. Relay Contacts: 24 VAC, 40 V peak, 1 A.

LTC 8902 Series Monitor Output Bays

The LTC 8902/60 and LTC 8902/50 include the equipment rack, LTC 8916/00 data receiver module, and LTC 8906 Series power supply.

Electrical

| Model No. | Rated Voltage | Voltage Range | Nominal Power ⁴ |
|-------------|-----------------------|---------------|----------------------------|
| LTC 8902/60 | 120 VAC, 50/60 Hz | 100 to 140 | 160 W |
| LTC 8902/50 | 220–240 VAC, 50/60 Hz | 198 to 264 | 160 W |

4. Power at rated voltage fully loaded.

Connectors

| | |
|-------------------------|---|
| Video Outputs | Four (4), 34-pin ribbon connectors used in conjunction with the LTC 8808/00 video interconnect panel |
| Video Bus Connections | Sixteen (16), 34-pin ribbon connectors interconnect with LTC 8903 Series Camera Input bays using LTC 8809/00 ribbon cables |
| Console | Port reserved for future use |
| COM 1 | Port reserved for future use |
| COM 2 | Port reserved for future use |
| EXT Sync | BNC input used to synchronize the unit to an external sync signal. Accepts composite video, composite sync, or the V Sync output provided from another LTC 8900 Series matrix bay |
| V Sync | BNC connector provides an output signal to synchronize an additional LTC 8900 Series matrix bay via its EXT Sync input |
| External Data Interface | Two (2), RJ-45 high-speed LAN ports for interface to the LTC 8901 Main CPU bay via system LAN Switches. (Connected in parallel; one is used, one is reserved for future use) |

Components

Equipment Rack

| | |
|------------------------|---|
| Dimensions (W x D x H) | EIA 48 cm (19 in.) rack, 483 x 420 x 267 mm (19 x 16.5 x 10.5 in.) |
| Weight | 11.1 kg (24.5 lb) |
| Construction | Metal cabinet |
| Finish | Charcoal |

Data Receiver Module (LTC 8916/00)

| | |
|------------------------|---|
| Dimensions (W x D x H) | EIA 48 cm (19 in.) rack, 483 x 420 x 267 mm (19 x 16.5 x 10.5 in.) |
| Weight | 0.5 kg (1.1 lb) |

Power Supply (LTC 8906/60 or LTC 8906/50)

| | |
|------------------------|---|
| Dimensions (W x D x H) | 67 x 360 x 247 mm (2.63 x 14.2 x 9.7 in.) |
| Weight | 5.2 kg (11.5 lb) |
| Indicators | Power On/Off and fuse alert LEDs |

LTC 8903 Series Camera Input Bays

The LTC 8903/60 and LTC 8903/50 include the equipment rack, LTC 8918/00 data receiver module, and LTC 8805 Series power supply

Electrical

| Model No. | Rated Voltage | Voltage Range | Nominal Power ⁵ |
|-------------|--------------------------|---------------|----------------------------|
| LTC 8903/60 | 120 VAC, 50/60 Hz | 100 to 140 | 85 W |
| LTC 8903/50 | 220–240 VAC, 50/60 Hz | 198 to 264 | 85 W |

5. Power at rated voltage fully loaded.

Connectors

| | |
|---------------------------------|--|
| Video Inputs | Sixteen (16), 34-pin ribbon connectors used in conjunction with the LTC 8808/00 video interconnect panel |
| Looping Video Input Connections | Sixteen (16), 34-pin ribbon connectors used with LTC 8809/00 ribbon cables (supplied as required to loop to additional LTC 8903 Series bays) |
| Video Bus Connections | Four (4), 34-pin ribbon connectors interconnect with LTC 8903 Series camera input bays using LTC 8809/00 ribbon cables |
| Console | Port reserved for future use |
| COM 1 | Port reserved for future use |
| COM 2 | Port reserved for future use |
| EXT SYNC | BNC input used to synchronize unit to external sync signal. Accepts composite video, composite sync, or the V Sync output provided from another LTC 8900 Series matrix bay |
| V SYNC | BNC connector provides output signal to synchronize an additional LTC 8900 Series matrix bay via its EXT Sync input |
| External Data Interface | Two (2), RJ-45 high-speed LAN ports for interface to LTC 8901 main CPU bay via system LAN Switches (Connected in parallel; one is used, one is reserved for future use) |

Components

Equipment Rack

| | |
|------------------------|---|
| Dimensions (W x D x H) | EIA 48 cm (19 in.) rack, 483 x 420 x 267 mm (19 x 16.5 x 10.5 in.) |
| Weight | 11.1 kg (24.5 lb) |
| Construction | Metal cabinet |
| Finish | Charcoal |

Data Receiver Module (LTC 8918/00)

| | |
|------------------------|---|
| Dimensions (W x D x H) | EIA 48 cm (19 in.) rack, 483 x 420 x 267 mm (19 x 16.5 x 10.5 in.) |
| Weight | 0.5 kg (1.1 lb) |

Power Supply (LTC 8805/60 or LTC 8805/50)

| | |
|------------------|---|
| Size (W x D x H) | 67 x 360 x 247 mm (2.63 x 14.2 x 9.7 in.) |
| Weight | 5.2 kg (11.5 lb) |
| Indicators | Power On / Off and fuse alert LEDs |

LTC 8921/00 Video Input Module

Use up to sixteen per LTC 8903 Series camera input bays

| | |
|---------------|-------------------------------|
| Camera Inputs | 32 |
| Size (D x H) | 300 x 250 mm (11.8 x 9.8 in.) |
| Weight | 0.41 kg (0.9 lb) |

LTC 8934/00 Video Output Module

Use up to eight per LTC 8902 Series monitor output bays

| | |
|--------------------|-------------------------------|
| Monitor Outputs | 8 |
| Dimensions (D x H) | 300 x 250 mm (11.8 x 9.8 in.) |
| Weight | 0.41 kg (0.9 lb) |

LTC 8941/91 System Controller

(Redundant System Configurations Only)

| | |
|---|---|
| Includes LTC 8943/93 PC, LTC 8944/92 Primary LAN Switch and LTC 8945/92 Backup LAN Switch | |
| LTC 8943/93 PC | Rack-mount industrial-grade Pentium PC, 256 MB RAM (minimum), 40 GB hard drive (minimum), CD-ROM drive, floppy drive, keyboard, mouse, keyboard/mouse rack-mount shelf, and Windows 2000; 120/220 VAC, 50/60 Hz |
| Monitor (MON152CL) | 38 cm (15 in.) active matrix LCD panel 120/230 VAC, 50/60 Hz |
| Monitor Rack (MON151RK) | Height: 31.12 cm (12.25 in.) Width: 48.26 cm (19 in.) |
| LTC 8944/92 Primary LAN Switch | 12-port 10/100Base-T Ethernet Switch with SNMP Module, programmed with primary IP Address; 120/220 VAC, 50/60 Hz |
| LTC 8945/92 Backup LAN Switch | 12-port 10/100Base-T Ethernet Switch with SNMP Module, programmed with back-up IP Address; 120/220 VAC, 50/60 Hz |

LTC 8946/92 Expansion LAN Switch

12-port 10/100BaseT Ethernet Switch, no SNMP module; 120/220 VAC, 50/60 Hz

LTC 8808/00 Video Interconnect Panel

The LTC 8808/00 assembly contains an interconnect panel which is used to convert 32 BNC connectors into two 16-channel ribbon cable connectors. The two (2) coaxial ribbon cables (LTC 8809/00), designed especially for use with video signals, and are then used to interconnect the video between the panel and the LTC 8900 system. Use of the LTC 8808/00 assemblies are required for all external video input and output connections. In addition to being used for video inputs and monitor outputs, the LTC 8808/00 assembly is also used to provide looping capability. One (1) LTC 8808/00 (includes panel and two ribbon cables) is required for each group of 32 system cameras or 32 monitors.

| | |
|-----------------------------------|---|
| Dimensions (W x D x H) | EIA 48 cm (19 in.) rack, 483 x 42 x 44 mm (19 x 1.65 x 1.75 in.) |
| Weight | |
| • Panel | 0.54 kg (1.2 lb) |
| • Ribbon Cables | Two (2), 0.3 kg (0.7 lb) |
| Construction | Metal |
| Finish | Charcoal |

Allegiant Accessories

The LTC 8900 Series accessory products provide many optional features to the base Allegiant switching systems. Accessory products include keyboard extension kits, Allegiant Bilinx Data Interface unit, receiver/driver units, switcher/followers, code merger units, and keyboard expansion units. All accessory products are designed to be installer-friendly and compatible throughout the Allegiant series systems. See the Allegiant Accessories data-sheet.

Americas:
Bosch Security Systems
130 Perinton Parkway
Fairport, New York, 14450, USA
Phone: +1 585 223 4060
Fax: +1 800 289 0096
security.sales@us.bosch.com
www.boschsecurity.us

Europe, Middle East, Africa:
Bosch Security Systems B.V.
P.O. Box 80002
5600 JB Eindhoven, The Netherlands
Phone: +31 40 27 83955
Fax: +31 40 27 86668
emea.securitysystems@bosch.com
www.boschsecurity.com

Asia-Pacific:
Bosch Security Systems Pte Ltd
38C Jalan Pemimpin
Singapore 577180
Phone: +65 6319 3450
Fax: +65 6319 3499
apr.securitysystems@bosch.com
www.boschsecurity.com

Represented by