



# LTC 88xx Series Allegiant Matrix/Control Systems - Modular



- ▶ 256 Camera by 64 monitor switching
- ▶ Expandable to larger matrix sizes
- ▶ Modular construction
- ▶ Powerful alarm handling capabilities
- ▶ SalvoSwitching and SatelliteSwitch capability
- ▶ PC-based software package available

The LTC 8800 Series Allegiant Video Switcher/Control Systems combine both switching and computer technology to provide powerful performance and unique system features for the security user. Offering full matrix switching capability, these systems can be programmed to display the video from any camera on any monitor, either manually or via independent automatic switching sequences.

## Functions

The LTC 8800 Series provide versatile modular construction, accommodating up to 256 camera inputs, 64 monitor outputs, 32 keyboards, 1024 alarm points, a computer interface port, and a logging printer port. These systems can be programmed with up to 60 sequences which can be run independently of each other in either a forward or reverse direction. Any of the sequences can utilize the SalvoSwitching capability, where any number of system monitors may be selected to switch as a group. Using the optional LTC 8059/00 master control software package or the LTC 8850/00 GUI Graphical User Interface, sequences can be made to activate and deactivate automatically based upon the time of day and the day of the week.

On-site receiver/drivers permit operator control of pan, tilt, zoom, multiple pre-positions, four auxiliaries,

autopan, and random scan. An integral local test function is also a standard feature. The LTC 8800 Series also support variable speed operation and full programming functions of AutoDome Series dome cameras.

When combined with an LTC 8016 Allegiant Bilinx Data Interface unit, these switcher/controllers support operations using Bilinx communication. With Bilinx, PTZ control is accomplished using a bidirectional communication protocol embedded in the video signal of Bosch Dinion and AutoDome CCTV cameras. In addition, Bilinx uses the standard video cable to transmit alarm and status messages from the cameras, providing superior performance without the need for separate data transmission cables.

With the addition of the LTC 8540/00 Series alarm interface accessory unit, an external contact closure or logic level can be used to automatically activate any camera to be displayed. Any monitor or group of monitors can be set to display cameras under alarm conditions. The base system contains three built-in alarm response modes: basic, auto-build, and sequence and display. In addition to these three modes, the PC-based software packages now include the ability to combine any or all the three standard modes within the same system. Alarm video may be selected to reset either manually or automatically. In addition, a 16-

character alarm title can be selected to appear instead of the camera title during alarm conditions.

System operation and programming is accomplished using a full-function, ergonomically designed keyboard. Up to 32 keyboards may be used in the system. Built-in operator priority levels and the ability to restrict certain operators from controlling designated functions provide maximum flexibility.

The LTC 8800 Series include a black outlined 48 character on-screen display for time/date, camera number, camera ID (16 characters), an icon to identify controllable cameras, and monitor (12 characters) or status information. Over 1000 characters are available when programming camera ID and monitor titles. Utilizing a standard Windows-based PC and the optional LTC 8059/00 Master Control Software package or LTC 8850/00 Graphical User Interface (GUI) software, enhanced programming and switching features can be obtained. A user friendly spreadsheet format provides the ability to enter camera titles, operator names, or 64 timed events; change system parameters; program camera sequences; install lockouts; and access the advanced alarm handling screens with speed and efficiency. The programmed information may then be transferred into the Allegiant system, stored on disk, or printed out directly from a printer connected to the PC. The LTC 8850/00 Bosch GUI software is designed around an intuitive graphic-based interface. The GUI provides high performance programming, control, and monitoring of all system functions by using on-screen icons to reflect real time status of the devices controlled by the system.

The LTC 8850/00 GUI software also provides the ability to monitor system status events. System alarms, switching functions, sequence events, keyboard actions, and video loss information can be viewed in real time on the PC screen and, if desired, logged to the PC hard drive.

The LTC 8800 Series contain a logging printer output port which accepts a standard RS-232 serial printer.

This provides a permanent record of system status showing the time and date of changes such as incoming alarms, acknowledgment of alarms, loading of sequences, user log-on to keyboard, transfer of system tables and sequences, video loss messages, and a power up reset message. In addition, the printer can be used to obtain a hard copy of the system's configuration tables and sequences.

The LTC 8800 system provides powerful macro capabilities. The macros can be activated using Allegiant Series system keyboards, system time event functions, alarm activations via special function icons in the LTC 8850/00 GUI software.

The LTC 8800 Series can serve as the master switcher in a SatelliteSwitch configuration. This innovative SatelliteSwitch feature enables a single LTC 8800 system to communicate with remotely located "Satellite" systems. Any Allegiant system model can serve as a remote Satellite switcher. This powerful feature permits the design of a large distributed type system with control at one central location and individual control at the local sites. The main control site can view/control local cameras plus cameras located at any of the remotely distributed Satellite sites. The Satellite sites can view/control only cameras associated with their own site. When used in this type of configuration, the main LTC 8800 system can access up to 2048 cameras located anywhere in the system. By combining multiple Satellite systems of this type, matrix sizes of 2048 cameras by 256 monitors can be designed in an extremely reliable "Distributed Processing" configuration.

**Certifications and Approvals**

Electromagnetic Compatibility (EMC)	Complies with FCC Part 15, ICES-003, and CE regulations
Product Safety	Complies with CE regulations, UL, CSA, EN, and IEC Standards

## Installation/Configuration Notes

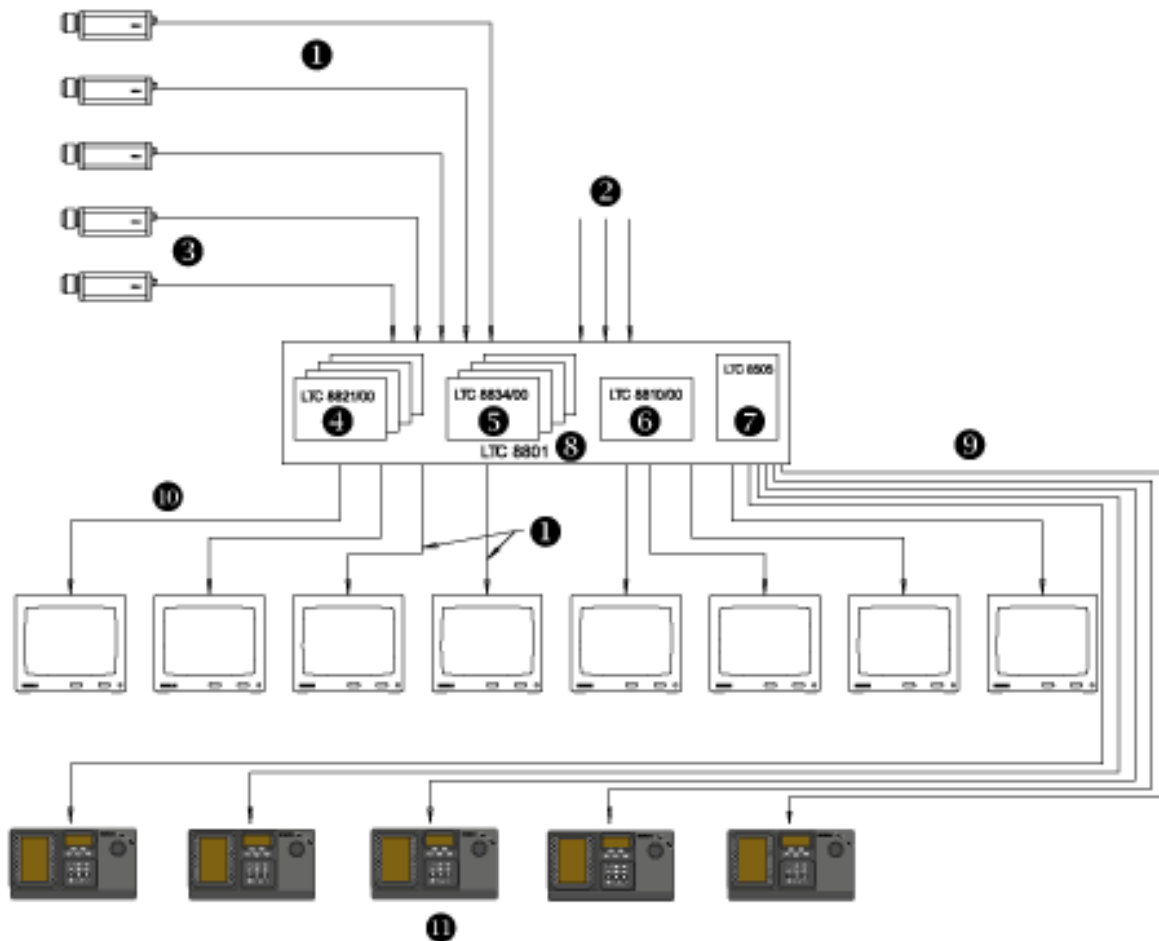

*LTC 8800 Series Configuration Diagram  
(256 Cameras by 32 Monitors)*

- |   |                           |    |  |
|---|---------------------------|----|--|
| 1 | Video Coax                | 6  | CPU Module   |
| 2 | 256 Camera Inputs Maximum | 7  | Power Supply Module  |
| 3 | Additional System Cameras | 8  | Series Main CPU Bay  |
| 4 | Input Cards               | 9  | 3m (10 ft) Interconnect Cable Supplied with Keyboard                       |
| 5 | Output Cards              | 10 | 32 Monitor Output Capacity   |
|   |                           | 11 | 32 Full Matrix Monitor Outputs Maximum, 32 Full Function Keyboards Maximum |

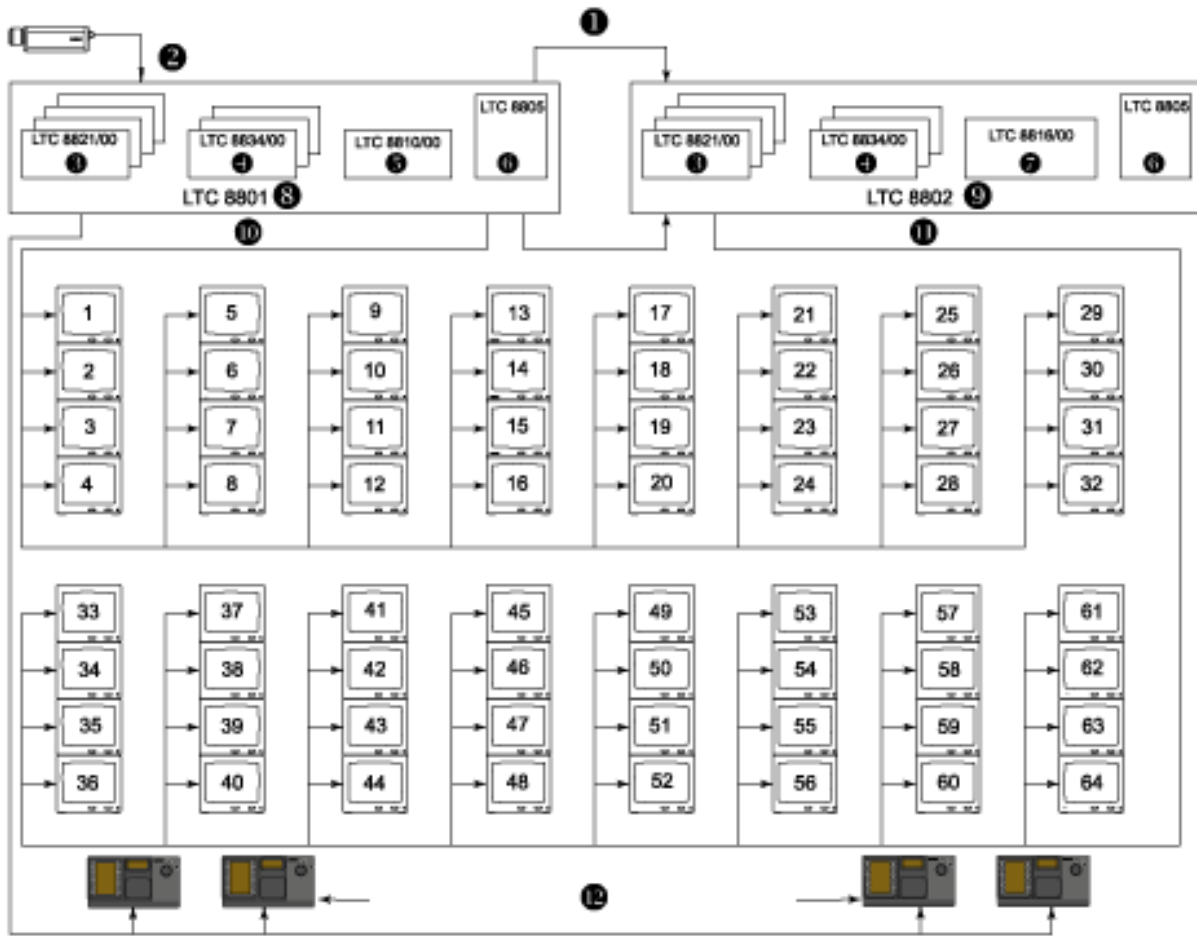

LTC 8800 Series Dual-bay System (256 Cameras by 64 Monitors)

- |  |   |
|--|---|
| 1 Coax Ribbon Jumper Cables (Supplied) | 7 Data Receiver Module  |
| 2 Up to 256 Cameras Total              | 8 Main CPU Bay  |
| 3 8 x 32 Channel Input Cards           | 9 Monitor Expansion Bay   |
| 4 8 x 4 Channel Output Card            | 10 Monitor Outputs 1 to 32  |
| 5 CPU Module                           | 11 Monitor Outputs 33 to 64   |
| 6 Power Supply Module                  | 12 Maximum of 32 Full-function Keyboards up to 1.5 km (5000 ft) away Using Optional Remote Hookup Kit |

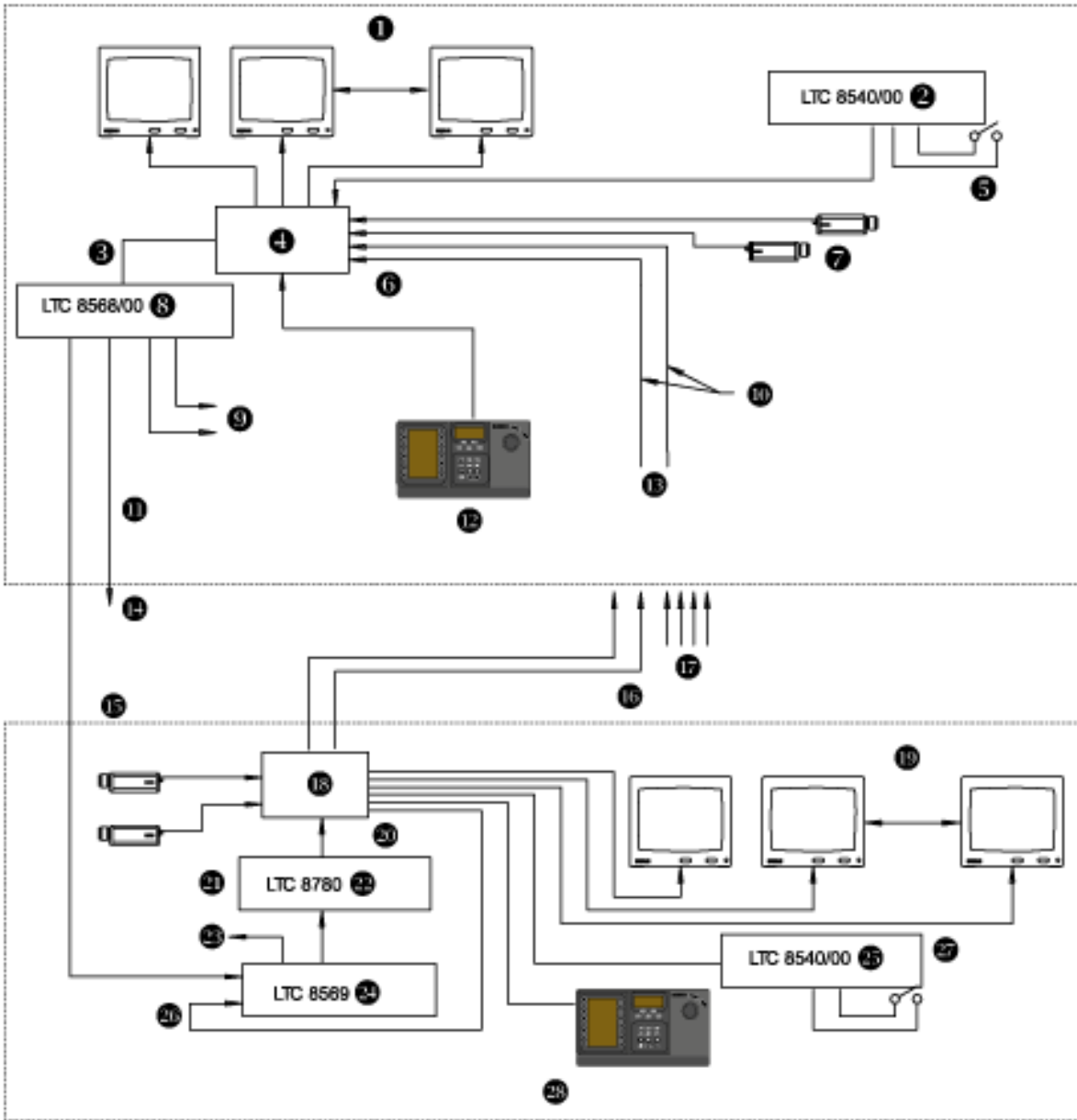

*Allegiant Satellite Switching System*

- |   |   |    |  |    |   |    |                               |
|---|---|----|--|----|---|----|-------------------------------|
| 1 | Monitor Outputs   | 15 | Pan/Tilt/Zoom and Satellite Control Data                       | 5  | Inputs Used for both Local and Trunk Lines  | 20 | Console Port Input            |
| 2 | Alarm Interface Unit  | 16 | Monitor Outputs Used as Video Trunk Lines to Main Control Site | 6  | Local Camera Video  | 21 | Satellite Data Line           |
| 3 | Pan/Tilt/Zoom and Satellite Control Data  | 17 | Video Trunk Lines from other Satellite Locations               | 7  | To any Local PTZ Camera Sites   | 22 | Data Converter Units          |
| 4 | Allegiant Main CPU Bay  | 18 | Any Model Allegiant Main Bay                                   | 8  | Multiple Video Coax   | 23 | To any Local PTZ Camera Sites |
| 5 | Alarm Inputs May Activate Either Local or Satellite Video Main Control Center's Monitor | 19 | Local Monitor  | 9  | Up to 1.5 km (5000 ft) using 1 mm <sup>2</sup> (18 AWG) Shielded Twisted Pair (Belden 8760 or Equivalent) | 24 | Code Merger Unit              |
|   |   |    |  | 10 |   | 25 | Alarm Interface Unit          |

- |    |   |    |   |
|----|---|----|---|
| 12 | Allegiant Keyboard Controls any Local or Remote Camera on any Local Monitor (Video and PTZ) | 26 | Local PTZ Control Data Line   |
| 13 | Multiple Video Trunk Lines from each Remote Satellite Location                              | 27 | Alarm Interface Unit only Local Video on Local Monitors                                 |
| 14 | One Line to Each Remote Satellite System Location   | 28 | Keyboard Controls any of the Local Cameras on any of the Local Monitors (Video and PTZ) |

## Technical Specifications

### LTC 8800 Series System Specifications

#### Capacities

<b>Video Inputs</b>	
Standard	256
Satellite Configuration	2048

<b>Video Outputs</b>	64
----------------------	----

<b>Keyboards</b>	32
------------------	----

<b>Alarm Inputs</b>	1024
---------------------	------

#### Receiver Drivers

Standard	256
Satellite Configuration	2048

#### Electrical

<b>Input Voltage Level</b>	0.5 Vp-p to 2 Vp-p (composite negative sync)		
----------------------------	---	--	--

<b>Gain</b>	Unity ± 4% (75 Ohm terminated)		
-------------	--------------------------------	--	--

<b>Pulse/Bar Ratios</b> <sup>1</sup>	Min.:	Nom.:	Max.:
	94%	98%	106%

<b>2T Pulse K Factor</b> <sup>1</sup>	Min.:	Nom.:	Max.:
		0.2%	2.5%

<b>Bar Amplitude (IRE)</b> <sup>1</sup>	Min.:	Nom.:	Max.:
	96	98	104

<b>Sync Amplitude (% Bar)</b> <sup>1</sup>	Min.:	Nom.:	Max.:
	36%	39%	44%

<b>Field Time Waveform Distortion</b> <sup>1</sup>	2% maximum
--	------------

<b>Line Time Waveform Distortion</b> <sup>1</sup>	1% maximum
---	------------

<b>Short Time Waveform Distortion</b> <sup>1</sup>	2% maximum
--	------------

<b>Long Time Waveform Distortion</b> <sup>1</sup>	0.8% maximum
---	--------------

<b>Video Bandwidth (-3 dB)</b> <sup>2</sup>	15 MHz
---	--------

<b>Frequency Response (± 0.5 dB)</b> <sup>2</sup>	12 MHz
---	--------

<b>Signal-to-Noise-Ratio</b> <sup>1</sup>	70 dB at 3.58 MHz unified, unweighted minimum.
---	---

<b>Crosstalk (at 3.58 MHz)</b>	Input to input: -60 dB adjacent channel: -50 dB (typical)
--------------------------------	--

<b>Hum</b>	60 dB below the composite 1 Vp-p video signal from 60 Hz to 6 MHz.
------------	--

<b>Differential Gain</b> <sup>1</sup>	Min.:	Nom.:	Max.:
	---	0.6%	2%

<b>Differential Phase</b> <sup>1</sup>	Min.:	Nom.:	Max.:
	---	0.6°	1.3°

<b>Chrominance Luminance Gain</b> <sup>1</sup>	Min.:	Nom.:	Max.:
	96%	100%	104%

<b>Chrominance Luminance Delay</b> <sup>1</sup>	Min.:	Nom.:	Max.:
	-33 ns	+3 ns	+33 ns

<b>Luminance Nonlinearity</b> <sup>1</sup>	Min.:	Nom.:	Max.:
	---	0.3%	4%

<b>Switching</b>	Crosspoint matrix
------------------	-------------------

<b>DC Output</b>	0.34 V
------------------	--------

1. Meets EIA/TIA - 250C Medium Haul Standard for 256 cameras x 32 monitors.

2. One camera to one monitor.

#### Environmental

##### Temperature

Operating	4°C to 50°C (40°F to 122°F)
-----------	-----------------------------

Storage	-40°C to 60°C (-40°F to 140°F)
---------	--------------------------------

<b>Altitude</b>	4500 m (15,000 ft)
-----------------	--------------------

<b>Humidity</b>	0% to 95% relative, non-condensing
-----------------	------------------------------------

<b>Vibration</b>	3 g swept sine wave, 15°Hz to 2000°Hz
------------------	---------------------------------------

<b>Shock</b>	50 g, 11 m/s, ½ sine wave
--------------	---------------------------

### LTC 8801 Series Main CPU Bay

Includes equipment rack, LTC 8810/00 microprocessor module, and LTC 8805 Series power supply.

#### Power

Model No.	Rated Voltage	Voltage Range	Nominal Power <sup>3</sup>
LTC 8801/60	120 VAC, 50/60 Hz	100 to 140	200 W
LTC 8801/50	220-240 VAC, 50/60 Hz	198 to 264	200 W

3. Power at rated voltage fully loaded.

#### Connectors

Video Inputs:	One (1) sync Input, and 32 monitor outputs BNC 1 to 96,
---------------	---

Video Connections: 97 to 256	Ten (10), 34-pin ribbon connectors used in conjunction with the LTC 8808/00 video interconnect panel (purchased separately)
------------------------------	---

Looping Video Connections: 1 to 256	Sixteen (16), 34-pin ribbon connectors used in conjunction with the LTC 8808/00 video interconnect panel (purchased separately)
-------------------------------------	---

#### External Accessory Interfaces

	9-pin D-type connectors
Console	RS-232 port for external PC or control interface (default = 19,200 baud)
Alarm	RS-232 port for Allegiant alarm accessory unit (default = 19,200 baud)
Printer	RS-232 port for system logging printer (default = 19,200 baud)
SDA	TTL level, high-speed control data output (Bi-Phase) for interface to Allegiant series signal distribution units (data clock rate = 31.25 kHz)
COMM Port 1	RS-485 port for interbay communication use (default = 125,000 baud)
COMM Port 2	RS-485 port for external Allegiant accessory use (default = 125,000 baud)
Keyboards	Eight (8), 6-pin RS-485 ports for Allegiant keyboard use (default = 9600 baud)

### Equipment Rack (LTC 8801)

**Size (W x D x H)** EIA 48 cm (19 in.) rack  
483 x 420 x 267 mm  
(19 x 16.5 x 10.5 in.)

**Weight** 11.1 kg (24.5 lb)

#### Construction/Finish

Top and Bottom Steel

Front, Sides, and Back Aluminum

Finish Charcoal

#### Microprocessor Module (LTC 8810/00)

**Size (D x H)** 300 x 250 mm (11.8 x 9.8 in.)

**Weight** 0.5 kg (1.1 lb)

#### Power Supply (LTC 8805/60–120 VAC, LTC 8805/50 – 220-240 VAC)

**Size (W x D x H)** 67 x 360 x 247 mm (2.63 x 14.2 x 9.7 in.)

**Weight** 5.2 kg (11.5 lb)

**Indicators** One power On/Off, ten fuse alert, and one external sync LED

### LTC 8802 Series Monitor Expansion Bay

Includes equipment rack, LTC 8816/00 data receiver module, and LTC 8805 Series power supply.

#### Power

Model No.	Rated Voltage	Voltage Range	Nominal Power <sup>4</sup>
LTC 8802/60	120 VAC, 50/60 Hz	100 to 140	200 W
LTC 8802/50	220–240 VAC, 50/60 Hz	198 to 264	200 W

4. Power at rated voltage fully loaded.

#### Connectors

Video Inputs: 1 to 96, and 32 monitor outputs BNC

Sync Input Not used

Video Connections: Ten (10), 34-pin ribbon connectors used in conjunction with the LTC 8808/00 video interconnect panel (purchased separately)

Looping Video Connections: Sixteen (16), 34-pin ribbon connectors used in conjunction with the LTC 8808/00 video interconnect panel

### External Accessory Interfaces

	9-pin D-type connectors
Console	Not used
Alarm	Not used
Printer	Not used
SDA	Not used
COM Port 1	RS-485 port for interbay communication use (default = 125,000 baud)
COM Port 2	Not used
Keyboards	Eight (8), 6-pin RS-485 ports for Allegiant keyboard use (default = 125,000 baud)

### Equipment Rack (LTC 8802 Series)

**Size (W x D x H)** EIA 48 cm (19 in.) rack,  
483 x 420 x 267 mm  
(19 x 16.5 x 10.5 in.)

**Weight** 11.1 kg (24.5 lb)

#### Construction/Finish

Top and Bottom Steel

Front, Sides, and Back Aluminum

Finish Charcoal

#### Data Receiver Module (LTC 8816/00)

**Size (W x D x H)** EIA 48 cm (19 in.) rack,  
483 x 420 x 267 mm (19 x 16.5 x 10.5 in.)

**Weight** 0.5 kg (1.1 lb)

#### Power Supply (LTC 8805/60–120 VAC, LTC 8805/50220–240 VAC)

**Size (W x D x H)** 67 x 360 x 247 mm (2.63 x 14.2 x 9.7 in.)

**Weight** 5.2 kg (11.5 lb)

**Indicators** One power On/Off, ten fuse alert, and one external sync LED

### LTC 8821/00 Camera Input Module

Use up to eight per bay in main CPU bay. If monitor expansion bay is being used, equip with duplicate number of modules.

**Camera Inputs** 32

**Size (D x H)** 300 x 250 mm (11.8 x 9.8 in.)

**Weight** 0.41 kg (0.9 lb)

### LTC 8834/00 Monitor Output Module

Use up to eight per bay in main CPU or monitor expansion bay.

**Monitor Outputs** 4

**Size (D x H)** 300 x 250 mm (11.8 x 9.8 in.)

**Weight** 0.41 kg (0.9 lb)

### LTC 8808/00 Video Interconnect Panel

NOTE: Use of the LTC 8808/00 assemblies are required for system video inputs 97 to 256 and must be purchased separately. The LTC 8808/00 assembly contains an interconnect panel which is used to convert 32 BNC connectors into two 16-channel ribbon cable connectors. The two, 16-conductor ribbon cables (LTC 8809/00), designed especially for use with video signals, and are then used to interconnect the video between the panel and the LTC 8800 Series system. In addition to being used for video inputs 97 to 256, the LTC 8808/00 assembly can also be ordered as an option to provide looping output capability. For looping purposes, one LTC 8808/00 (includes one panel and two ribbon cables) is required for each group of 32 cameras.

The following table can be used to determine the number of LTC 8808/00 assemblies that must be purchased:

Number of System Cameras	Number of LTC 8808 Assemblies Required for Camera Input Connections Only	Number of LTC 8808 Assemblies Required for Inputs and Looping Video Outputs
1 to 32	None	1
33 to 64	None	2
65 to 96	None	3

97 to 128	1	5
129 to 160	2	7
161 to 196	3	9
197 to 224	4	11
225 to 256	5	13
<b>Finish</b>	Charcoal	
<b>Size (W x D x H)</b>	EIA 48 cm (19 in.) rack, 483 x 42 x 44 mm (19 x 1.65 x 1.75 in.)	
<b>Weight</b>		
Panel	0.54 kg (1.2 lb)	
Ribbon Cables (2)	0.3 kg (0.7 lb)	

#### Allegiant Accessories

The LTC 8800 Series accessory products provide many optional features to the base Allegiant switching systems. Accessory products include keyboard extension kits, Allegiant Bilinx Data Interface unit, receiver/driver units, switcher/followers, code merger units, and key-board expansion units. All accessory products are designed to be installer-friendly and compatible throughout the Allegiant series systems. See the Allegiant Accessories datasheet.

#### Ordering Information

LTC 8801/50 Allegiant Matrix Switcher Includes equipment rack, LTC 8810/00 micro-processor module and LTC 8805 Series power supply; 220-240 VAC, 50/60 Hz	896088015001
LTC 8801/60 Allegiant Matrix Switcher Includes equipment rack, LTC 8810/00 micro-processor module and LTC 8805 Series power supply; 120 VAC, 50/60 Hz	896088016001
LTC 8821/00 Video Input Module for LTC 8800, 32 video inputs per card	896088210001
LTC 8834/00 Video Output Module for LTC 8600 and LTC 8800, 4 video outputs per card	896088340001
LTC 8808/00 Video Interconnect Panel 32 channel, for Allegiant systems, includes two LTC 8809/00 ribbon cables	896088080001
LTC 8809/00 16-Conductor Ribbon Cable for LTC 8200, 8300, 8600, 8800, 8900 systems, 2 m (6 ft)	896088090001

#### Hardware Accessories

LTC 8805/50 Spare Power Supply for LTC 8601/50, LTC 8802/50 bays, 220-240 VAC, 50 Hz	896088055001
LTC 8805/60 Spare Power Supply for LTC 8902/8903 bay, 120 VAC	896088056001
LTC 8816/00 Data Receiver Module for LTC 8802/00, 0.5 kg (1.1 lb)	896088160001

**Americas:**  
Bosch Security Systems  
130 Perinton Parkway  
Fairport, New York, 14450, USA  
Phone: +1 585 223 4060  
Fax: +1 800 289 0096  
security.sales@us.bosch.com  
www.boschsecurity.us

**Europe, Middle East, Africa:**  
Bosch Security Systems B.V.  
P.O. Box 80002  
5600 JB Eindhoven, The Netherlands  
Phone: +31 40 27 83955  
Fax: +31 40 27 86668  
emea.securitysystems@bosch.com  
www.boschsecurity.com

**Asia-Pacific:**  
Bosch Security Systems Pte Ltd  
38C Jalan Pemimpin  
Singapore 577180  
Phone: +65 6319 3450  
Fax: +65 6319 3499  
apr.securitysystems@bosch.com  
www.boschsecurity.com

**Represented by**