

TOMSED MODEL TST-75ES GRAND PRIX TURNSTILE



THE WORLD'S MOST SOPHISTICATED
ACCESS CONTROL TURNSTILES.



TOMSED CORPORATION

420 McKinney Parkway • Lillington, NC 27546
P: (910) 814-3800 • F: (910) 814-3899 • 800-334-5552

E-mail: sales@tomshed.com

Visit our website @ www.tomshed.com

SECURITY & TRANSIT CONTROL SYSTEMS

TOMSED MODEL TST-75ES

OPERATION

- The TOMSED Model TST-75ES Grand Prix Electronic Turnstile is designed for very high volume, abusive access control applications where a premium is placed on low maintenance and reliability.
- The electronic control board will easily interface with any access control device. The electrical system includes a 24 VDC low voltage power supply.
- The turnstile can be: controlled entry, no exit - controlled entry, free exit - or controlled entry and controlled exit. Any combination of fail-lock or fail-safe is available to suit system requirements.

CONSTRUCTION

- The heavy duty modular electrical operating mechanism is the same as that supplied in TOMSED Transit turnstiles for systems such as New York, Boston, Miami, Atlanta, Monterrey, and Hong Kong.
- Standard self-centering feature automatically returns arm assembly to the home position regardless of force used to pass through the turnstile, thereby assuring an accurate count and record of passage.
- The cabinet is made of durable 16 gauge 304 stainless steel, polished to a 4B finish. A lockable cover attaches via an internal hinge to allow convenient access.
- Two lockable access doors allow concealed anchoring and wiring of electrical harness.

SPECIFICATIONS

- A normally open, momentary dry contact is required to activate each controlled direction.
Height: 38" Passage Space: 18" Minimum Weight: 135 lbs. NET
Width: 8" Cabinet Length: 36" 180 lbs. Crated

DIMENSIONS

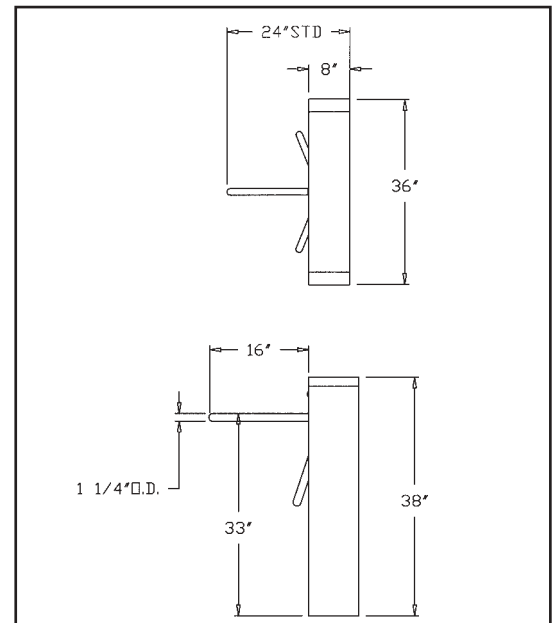

ORDERING INFORMATION

- The base model is a TST-75ES which provides one-way electrical operation with either a free exit or no exit. If independent bi-directional electrical operation is required, the model is a TST-75ES2.

AVAILABLE OPTIONS

- | | |
|---------------------------------|-----------------------|
| Time out Relay | Electronic Key Bypass |
| Pulse Relay | Out-of-Use Lock |
| Red and Green Indicator Lights | Counter |
| Extended Arms to Increase Aisle | Platform and Railing |
| Rotation Detection Switch | Coin/Token Operation |
| Remote Release Button | Alphanumeric Display |



TOMSED CORPORATION
420 McKinney Parkway • Lillington, NC 27546
P: (910) 814-3800 • F: (910) 814-3899 • 800-334-5552
E-mail: sales@tomsed.com
Visit our website @ www.tomsed.com